



The KISSsoft Interface to Inventor

Calculate, generate and document gears in 3D with KISSsoft and easily integrate them into Inventor, and more!

KISSsoft

KISSsoft is a comprehensive CAE package for the layout, analysis and optimization of machine elements.

For our gear calculation software modules, we have developed an interface to Inventor. You can now calculate your gears in KISSsoft and, with the push of a button, create and display them in Inventor.

As an additional feature, the KISSsoft interface offers you an add-in to Inventor. You can now call all KISSsoft calculation modules directly from the CAD program.

We could thus eliminate the laborious construction and the manual transfer of parameters from CAE to the CAD package. With KISSsoft and its interface, it is possible to keep it all under one umbrella.

Gear types

The Inventor Interface supports the following gear types:

- Internal / external Spur Gears
- Internal / external Helical Gears
- Crossed Axes Helical Gears
- Worm Gears
- Bevel Spur Gears

The KISSsoft Interface supports Inventor Versions V9, V10 and V11.

The Interface

Generation of a gear model can take place in one of two ways. A gear can be generated for an existing assembly or as a completely new part.

The interface attaches the KISSsoft calculation files, as well as the required manufacturing information for the twodimensional drawings, to the Inventor Part (see next page in section manufacturing data).

Gears are generated either with polylines or by circular approximation. It is up to you to decide which format to choose.

KISSsoft's Inventor Interface is, intended for your international application, available in following languages: English, German, French, Italian and Spanish.

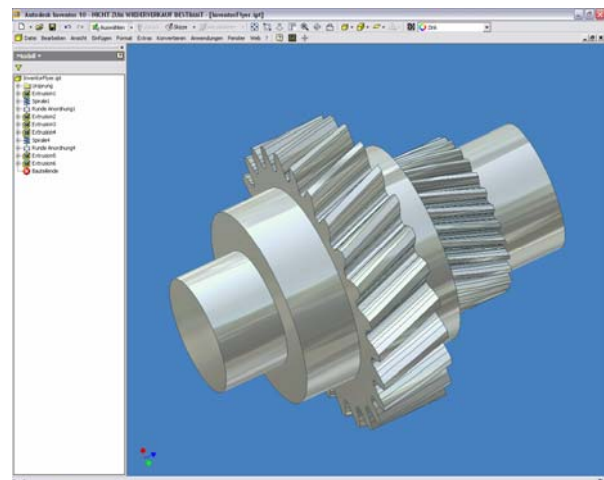

KISSsoft Display of Helical Spur Gears

Spur and Helical Gears

KISSsoft calculates the geometry and the strength of spur gear pairs and helical gear pairs as well as planetary gear trains.

The exact generation of the tooth form is guaranteed by the manufacturing simulation. With this data, Inventor will generate the Spur or Helical Gears, both internal and external. Furthermore, several gears can be created on already existing shafts.

The admissible tooth thickness tolerance deviation is implemented in the KISSsoft Calculation and is also taken into consideration in the 3D Display. This display can also consider minimal, middle and maximal tolerance.

Bevel Gears

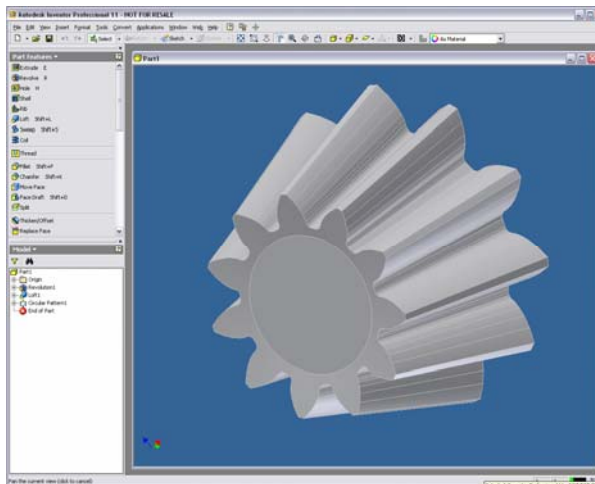

KISSsoft Display of a Bevel Spur Gear

The strength calculation of bevel gears according to DIN, ISO or Klingelnberg methodologies is easily accomplished in KISSsoft. In Inventor, it is also possible to generate Bevel Spur Gears according to DIN 3971 methodologies, see Figure.

Calculation and Manufacturing Data

The calculation and manufacturing data are directly attached to the tooth profile. This means for you, as end-user, that the drawing will also contain all relevant manufacturing data.

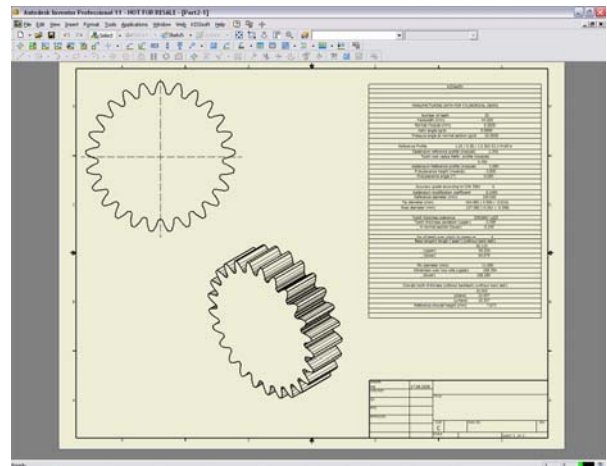

Manufacturing drawing with manufacturing data

By selection of the tooth in Inventor the interface takes you back to your KISSsoft calculation. This is a convenient method to implement changes. Through this, access to all necessary information from gear design to the manufacturing is ensured.



For further information and a gratis test version, please contact your CAD Partner or visit us at the KISSsoft Web page. You can also call us at +41 55 264 20 30 and ask for Mr. Noske, who will be your direct partner.