

KISSsoft AG - +41 55 254 20 50
 Uetzikon 4 - +41 55 254 20 51
 8634 Hombrechtikon - info@KISSsoft. AG
 Switzerland - www. KISSsoft. AG

KISSsoft Tutorial: Keys

1 Starting KISSsoft

1.1 Starting the software

Once you have installed and activated KISSsoft either as a test or licensed version, follow these steps to call the KISSsoft system. Usually you start the program by clicking "Start→Program Files→KISSsoft 03-2011→KISSsoft". This opens the following KISSsoft user interface:

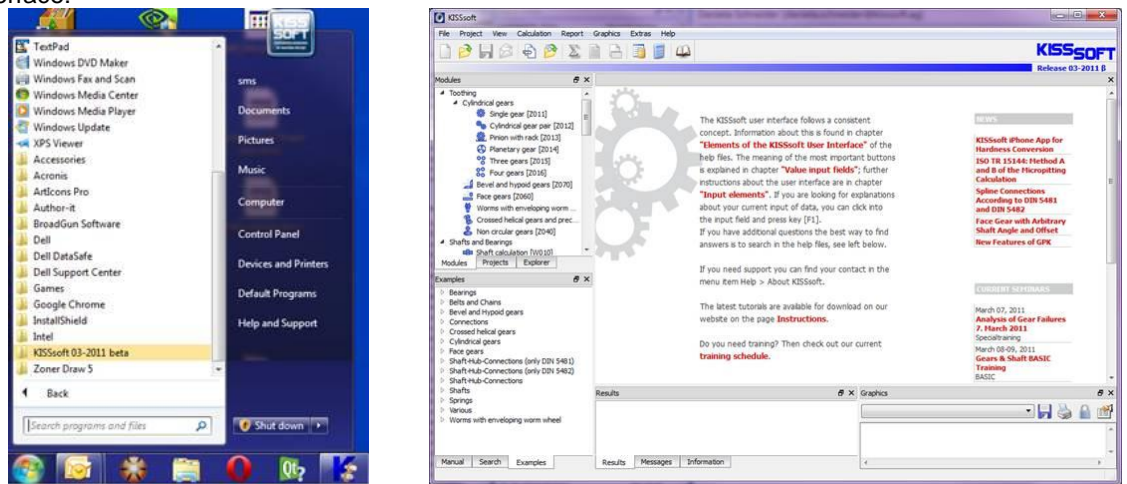

Figure 1.1 Starting KISSsoft, initial window

1.2 Selecting a calculation

In the Modules tree window, select the "Modules" tab to call the calculation for keys:

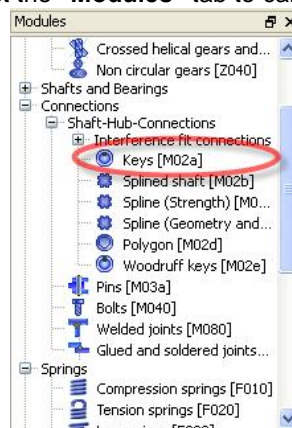

Figure 1.2 Selecting the "Key" calculation module under Shaft-Hub-Connections

2 Analysis of a key

2.1 Task

To size and analyze a key (in accordance with DIN 6892, Method B) for the following geometry and load data:

Shaft diameter	120 mm	Nominal torque	4000 Nm
External diameter, hub D1	200 mm*	Maximum torque	15000 Nm
External diameter, hub D2	270 mm	Application factor	1.50
Width for external diameter D2 within the carrying length c	17 mm	Frequency of load peak	10000
Distance a_0	96 mm	Frequency of change in sense of rotation	250'000
Key as specified in	DIN 6885.1 A32x18x125	Slowly alternating torque	
Number of keys	1	Material hub	GG25
Chamfer shaft	none	Material key	C45
Chamfer hub	0.8 mm	Material shaft	C60
		Supporting length l_r	125-32=93 mm

*As there are 10 holes in part 1 (64 mm diameter) to accommodate the elastic elements of the coupling, the hub is less rigid under torsion. Therefore, the pitch diameter is used to calculate the replacement cylinder instead of the outer diameter of the hub.

At present, there are two different analysis methods available in the KISSsoft system for verifying the strength of keys. You can select these either in the module-specific settings under **"Calculation" → "Settings"**, or call them directly by clicking the button in the command list.

Method C specified in the DIN standard is a simplified method and will not be discussed here. The standard analysis method specified in DIN 6892, Method B, is used as the default setting, and can therefore be used in this example (see Figure 2.1)

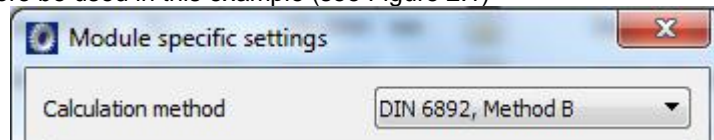

Figure 2.1 Selecting DIN 6892, Method B as the analysis method

The following material properties are predefined here:

	Yield point Re [MPa]	Tensile strength Rm [MPa]
EN-GJL-250 (GG 25) (brittle)	130	200
C45 K (cold drawn)	430	680
1C60 N (normalized)	310	600

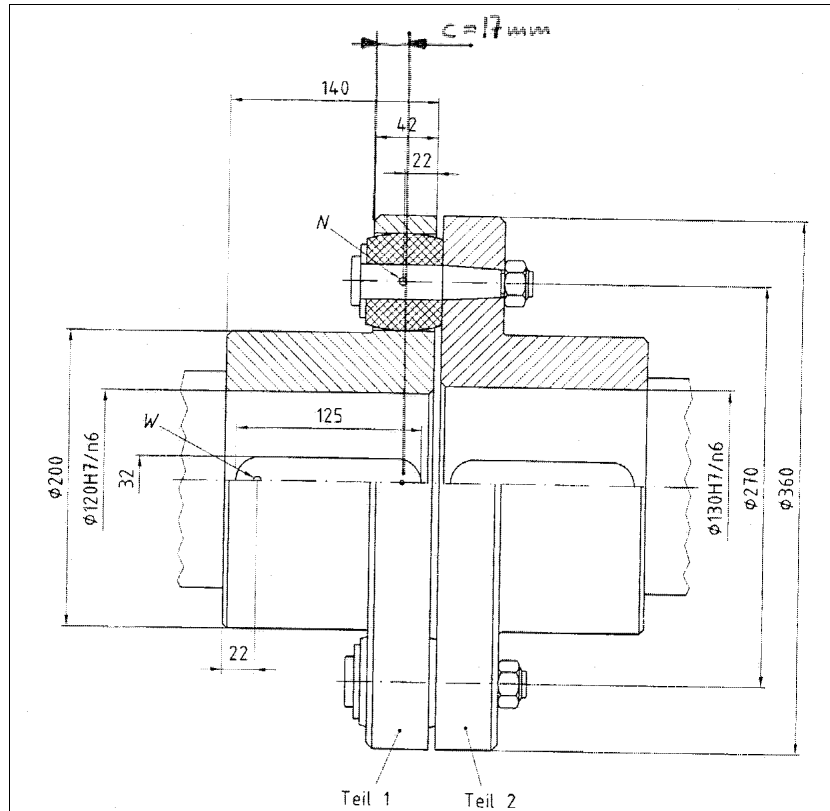

Figure 2.2 Structure of the entire connection. Part 1 is to be proved

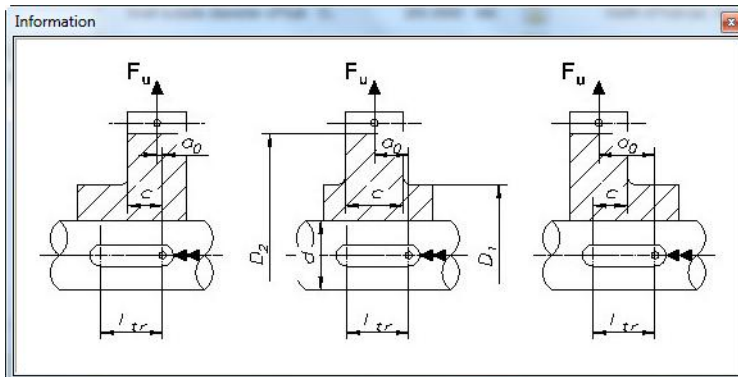
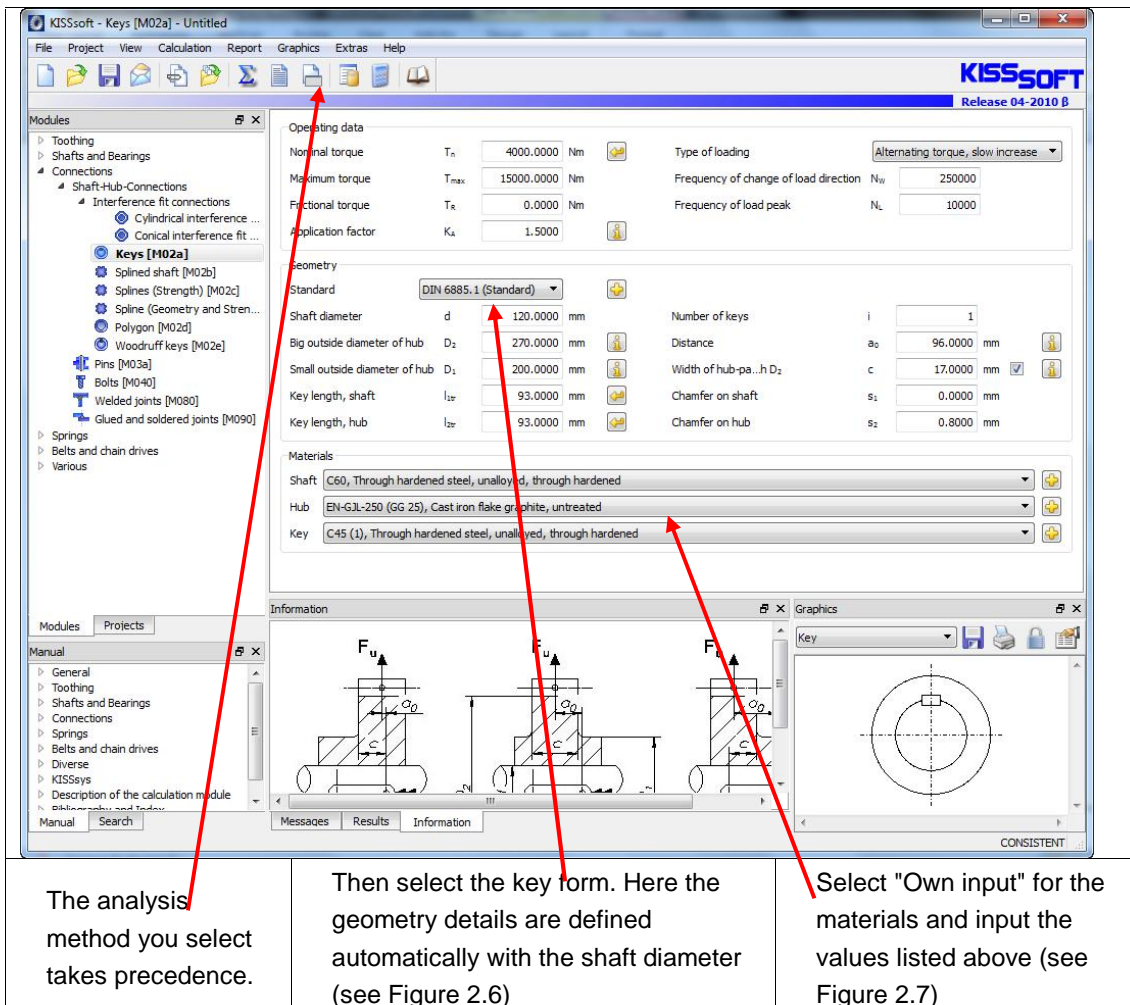

Figure 2.3 Definition of D_2 , D_1 , a_0 and c

2.2 Entering the data

Enter this data as follows:



The analysis method you select takes precedence.

Then select the key form. Here the geometry details are defined automatically with the shaft diameter (see Figure 2.6)

Select "Own input" for the materials and input the values listed above (see Figure 2.7)

Figure 2.4 Input window - Inputting loads and main dimensions

Input the detailed geometry, as shown in Figure 2.5, as follows:

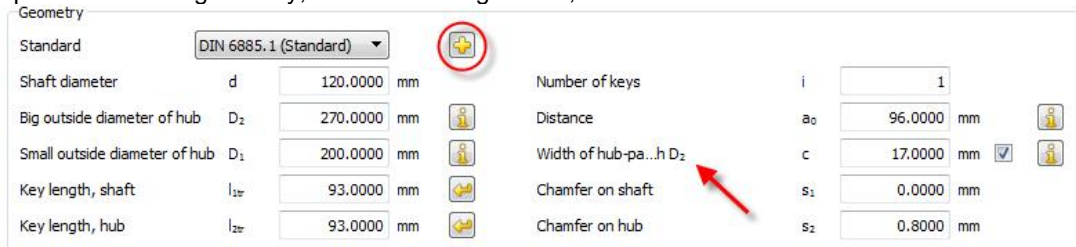



Figure 2.5 Input window, group: "Geometry" - Details of hub geometry for a shouldered hub

You can input the hub geometry, especially for a shouldered hub, as specified in , directly via the interface.

You can specify the value for the width of the hub outer diameter D2 within the supporting length c. If a shouldered hub is present, set the flag in the "Checkbox" to influence the values. If no shouldered hub is present, these values are set automatically.

Click the "Plus button" to display details of the key's geometry , see marking in Figure 2.6:

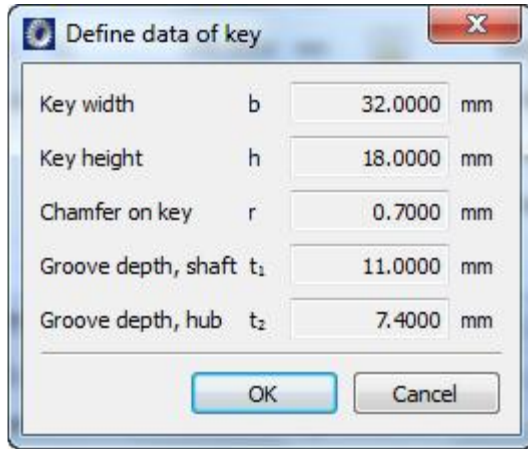

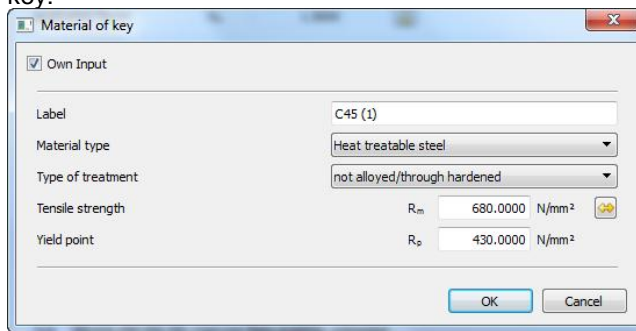

Figure 2.6 Information about the selected key

The detailed geometry of the key is determined from the shaft diameter and selected key standard. You can also input your own key dimensions.

In addition, you must input material data (because this is not included in the database). To do this, click the "Plus button"  to the right of the materials selection list for the shaft, hub and key:



Definition of key material. This is where you specify the values for yield strength and tensile strength.

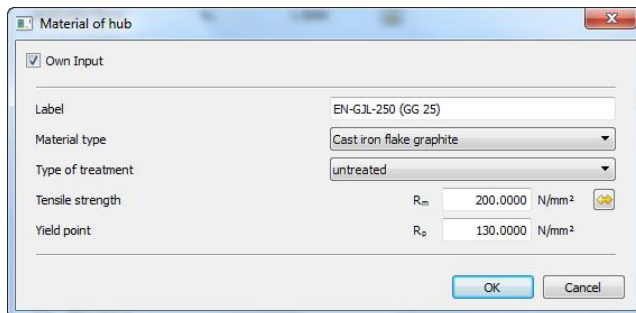

When defining the material for the hub, it is important you select the correct material type here. As the material used in this example is a brittle material, it has an effect on the analysis (for example, the permissible stresses are calculated on the basis of the material's tensile strength and not from the yield strength).

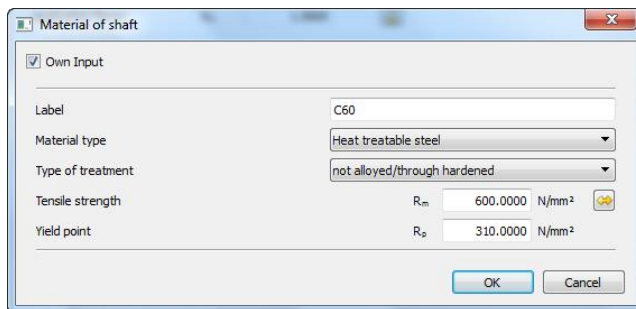

Input shaft material data.

Figure 2.7 Selecting values for materials



2.3 Running the analysis and report

Click  in the tool bar or press "F5" to start the calculation. Some of the results then appear in the lower part of the main window (stresses on the elements, safety factors etc). Note the status bar shows that the results are "CONSISTENT". This tells you that the input data matches the displayed results (for example, if you now change the nominal torque, the display



changes to "INCONSISTENT" and remains like this until you run the calculation again by clicking  or pressing "F5").

The key is analyzed as specified in DIN 6892. This calculation is particularly suitable for static loads, but can also be used for pulsating or alternating loads, with a few constraints. However, it is usually the shaft and not the key that is the critical element and must therefore be checked in the shaft analysis (see also section 3).

During the calculation in KISSsoft the load supporting length of the key is always used, no matter what the key form (here $l_{tr}=93$ mm). The frictional torque has to be calculated in another module (for example, in the interference fit module) and must be predefined. If it is not known, set this value to zero. The safety factors shown are the minimum safety due to nominal and maximum torque (minimum of static and proof of fatigue strength) as well as stress from nominal torque. Here the application factor is only used for nominal load.

Click the "Generate report" icon  (to the right of ) or press "F6" to create an analysis report which lists all the calculation parameters (see also section 2.5). You can now include this report, for example, in a formal strength report.

2.4 Calculation of maximum permissible torque

In a second step, you can now calculate the nominal torque required to achieve a minimum safety factor of 1.20. To do this, go to **"Module specific settings"** (see Figure 2.8), set the required safety factor to 1.20 and then click the "Sizing" button  (1) to the right of the nominal torque field. The maximum permissible nominal torque is then calculated to be 3305 Nm. If you then press  again (2), the minimum resulting safety factor will then be the required safety of 1.20. See the lowest markings (3) in Figure 2.9.

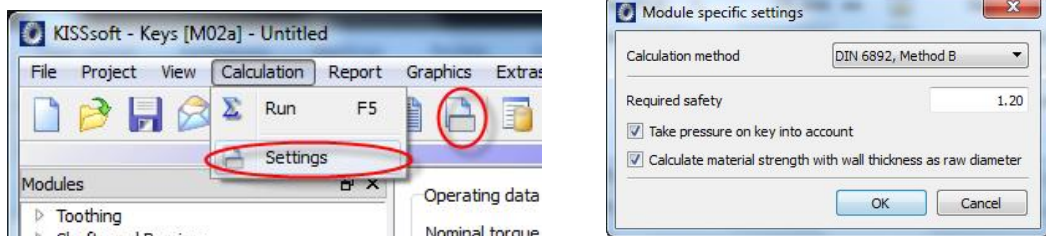

Figure 2.8 Module-specific settings

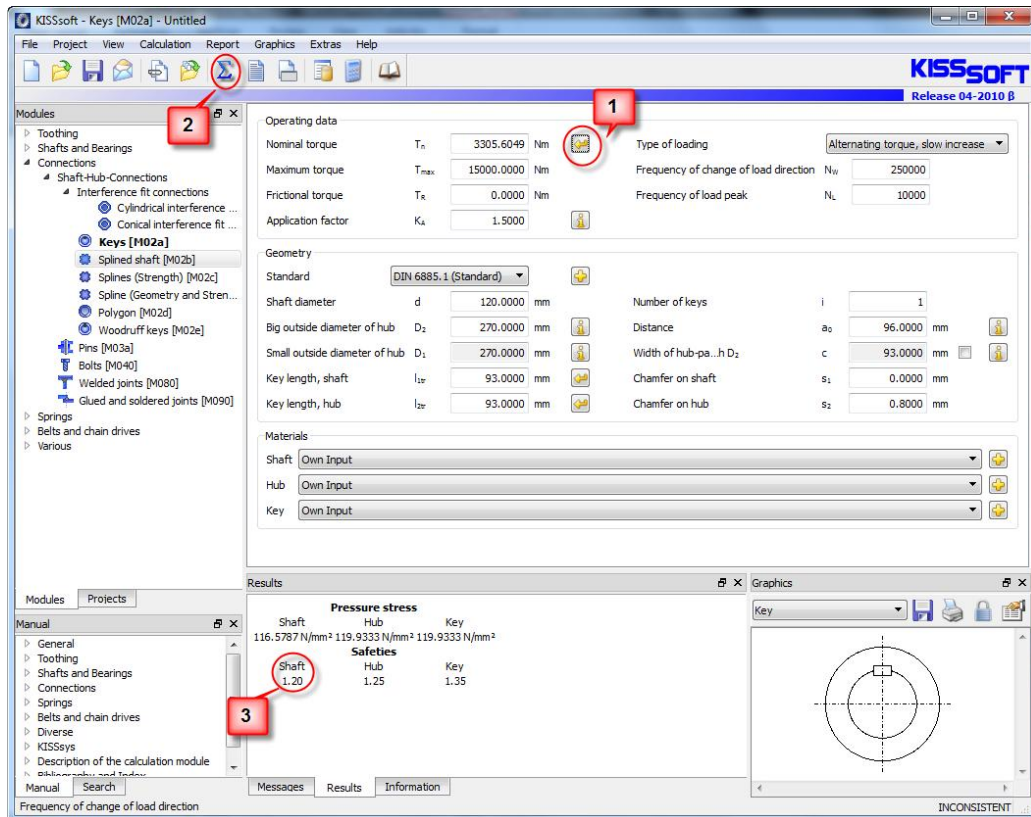



Figure 2.9 Defining the maximum permissible nominal torque

- (1) Click  to calculate the maximum nominal torque.
- (2) The calculation process then returns the required safety factor (3).

2.5 Comments on the report

Some comments about the parameters listed in the report:

- Equivalent torque: $T_{eq} = K_A \cdot T_{nenn}$, K_A from DIN 3990
- Circumferential force from torque: $F_{eq} = T_{eq}/r$, $F_{max} = T_{max}/r$
- Definition of supporting length, l_{tr} and depth t_{tr}
- Surface pressure from circumferential force, contact area and load factor K_V : depending on the number of keys used; maximum of 2 keys included in the analysis, $K_V = 0.75$ (higher for maximum surface pressure (key deformation), $K_V = 0.9$)
- Load distribution coefficient K_I , uneven load distribution over the length of the key friction factor K_R : accounts for part of the torque being transmitted via an interference fit. Only used for peak torque.
- No oversize modifications present if brittle materials are used for hubs Load direction changes coefficient f_W : takes into account the frequency of changes in load direction; different for abrupt or slow changes
- Frequency of peak load factor f_L : factor considering the frequency of peak loads, different for ductile and brittle materials
- Support factor f_S : support effect for materials loaded under pressure, depends on the material
- Hardness influence coefficient f_H : for hardened surfaces
- Permissible contact stress from R_e or $R_{p0.2}$ for ductile and R_m - for brittle materials and the above factors
- Validity range of the analysis: metallic materials for temperatures from -40°C to 150°C

3 Shaft Analysis

3.1 General

From research previously performed on key connections, it has been established that it is usually the shaft that is the critical part of the connection. Keys only shear in very exceptional situations, if at all, and only under peak loads. Numerous fatigue tests with keys have shown that the corrosion effects due to alternating bending action (due to rotary bending and/or alternating torsion) are the most common cause of damage to the keys, and cause the connection to fail. A complete proof of strength for the connection also includes analyzing the surface pressure on the shaft, key and hub, shaft strength and hub strength. In this case, the hub strength is not a critical factor. The KISSsoft key analysis only provides proof for contact stresses. Use KISSsoft shaft analysis to obtain the proof against fatigue failure of the shaft.

3.2 Notch factors for shaft analysis

As damage (in particular for the shaft) is caused by a combination of notch stresses and corrosion, it is not sufficient to merely observe a notched shaft to determine the notch factors. Tests must be performed on the entire connection to ascertain these notch factors. As these experiments involve a large number of parameters, the data for notch factors used in shaft analysis can be very different, and is usually defined only in a range.

It is therefore the engineer's responsibility to carefully review the notch factors used in the shaft analysis.

For example, see:

- DIN 6892, Passfedern, Berechnung und Gestaltung
- U. Oldendorf, Lebensdauer von Passfederverbindungen, VDI report 1790
- E. Leidich, Einfluss des Schwingungsverschleisses auf die Tragfähigkeit von Welle-Nabe-Verbindungen, VDI report 1790
- DIN 743, Tragfähigkeit von Wellen und Achsen